

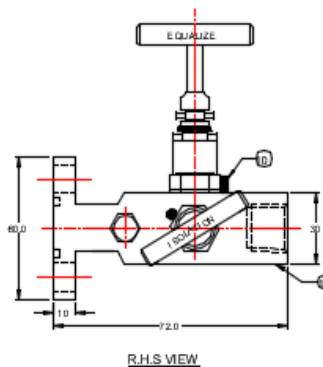

3VM – Pipe to Flange

Model : CEI-3-MV-T

With threaded horizontal port inlets on the front side and Flange outlets on the back side. Two test connections positioned on the left and right hand side of the body. The isolating bonnets are positioned on the left and right hand side and the equalizing bonnet is positioned on the top.

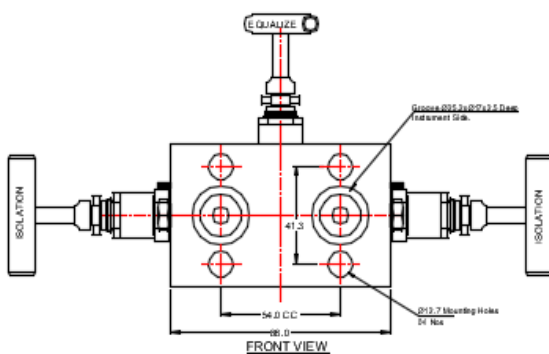
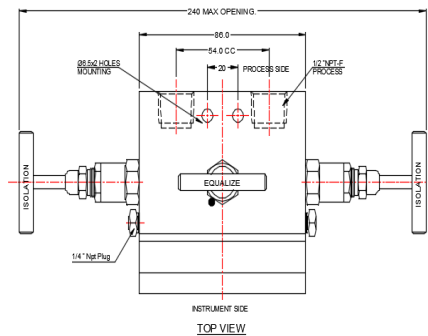
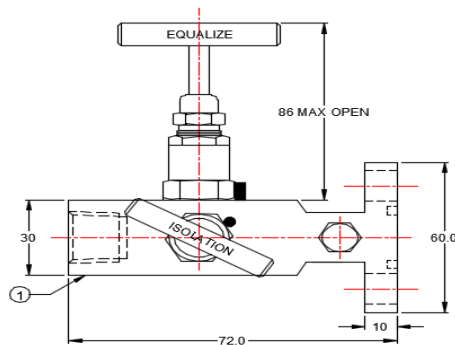
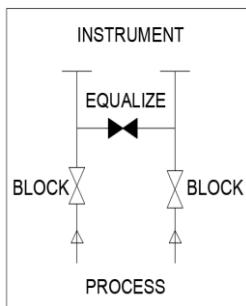
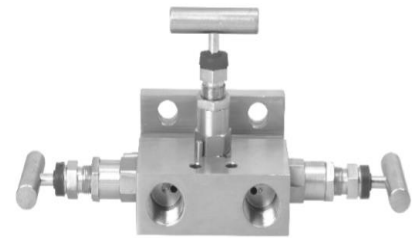

Technical Specification

- Max. Pressure : 400bar / 6000psi
- Max. Temperature : 240° C
- Material : SS304 / SS316, A105
SS304L/SS316L,
Monel, Hastelloy, Inconel,
- Gland Packing : PTFE, Graphite
- Std. Process Connection : 1/2" NPT (F)
- Std. Drain Connection : As per customer requirement