

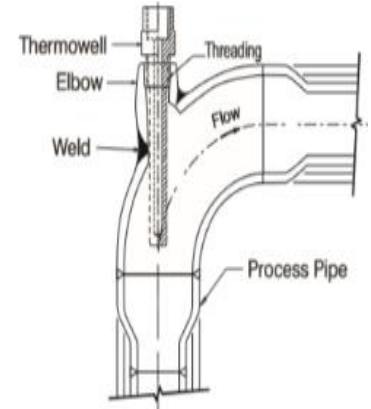

V. Fabricated (Screwed)

- These Thermowells are fabricated from pipe with a welded end cap.
- These thermowells are installed directly into the process with the help of threaded process connection.
- Ideal for use in longer length tank & vessels where bar stock is a limitation.



Thermowells Installation

Applications

HVAC Industries, Utilities, Chemical plants, Pharmaceutical, Engineering Plants, On shore, ff shore & other similar process industries.

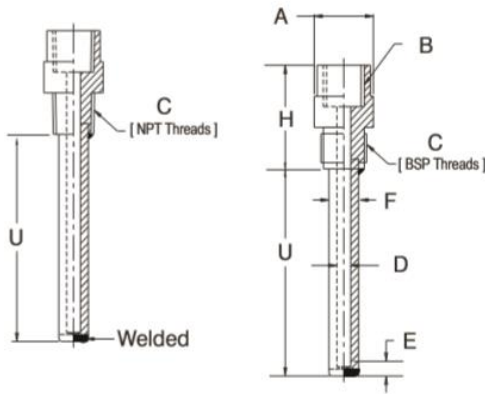

- A - Finished Head Size
- B - Instrument Connection
- C - Process Connection
- F - Major Diameter (As per Pipe Schedule)
- D - Bore Diameter (As per Pipe Schedule)
- E - Tip Thickness
- U - Insertion Length
- H - Extension Length

Technical Description:

Type	: Straight
Material	: SS316/SS304, SS304L/SS316L, Monel, Inconel, Hastelloy, Carbon Steel
Instrument Connection	: 1/2" to 1" (NPT & BSP)
Process Connection	: 1/2" to 1" (NPT&BSP)
Type of Head	: Hex headed, Round headed with spanner slots
Extension	: H50 (Standard)
Major Diameter	: 1/4", 3/4", 3/8", 1/2" (Sch 40 to 160)
Test & Certification	: Dye Penetration Test, PMI Test, Chemical Composition Test.